

STEP ONE

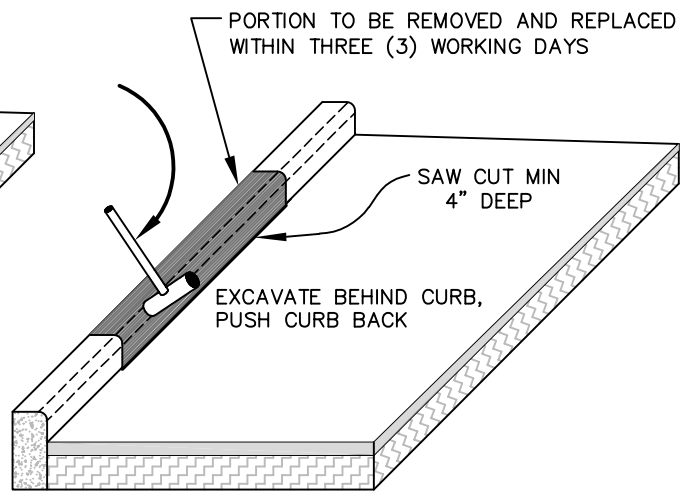

STEP TWO

- NOTES:**
1. CURB SECTION SHALL BE REMOVED IN ACCORDANCE WITH DRIVEWAY WIDTH APPROVED BY THE TOWNSHIP.
 2. IF PERPENDICULAR CUT IS WITHIN 12 INCHES FROM A JOINT, THEN THE CUT SHALL BE MADE TO THAT JOINT.
 3. THIS METHOD IS NOT ALLOWED IN NEW SUBDIVISION CONSTRUCTION.
 4. CURB REMOVAL ALONG EXISTING ROADWAYS SHOULD BE COMPLETED BY SAW-CUTTING ALONG THE EXISTING/PROPOSED CURB FACE, EXCAVATING BEHIND THE CURB, AND PULLING THE CURB AWAY FROM THE ROAD IN ORDER TO MINIMIZE/ELIMINATE ROADWAY WORK.

STANDARD METHOD OF REMOVING EXISTING CURB
(FOR A DRIVEWAY APRON INSTALLATION)



**PEQUANNOCK
TOWNSHIP**
530 NEWARK-POMPTON TPK
POMPTON PLAINS, NJ 07444
PHONE (973) 835-5700
FAX (973) 835-9396

CURB REMOVAL
STANDARD DETAIL
ENGINEERING DEPARTMENT
PEQUANNOCK TOWNSHIP
MORRIS COUNTY **NEW JERSEY**
SCALE: N.T.S. DATE: 7/19/2019 SHEET 1 OF 1